

TIG TTS 18

Torçe Tig 350A H2O

Dati Tecnici TTS 18

V Class	L
Lz max (100% Argon)	350
V (Ac or Dc)	AC-DC
Ø Filo	1,0-4,0 mm
Gas	6-20 l/1'
Raffreddamento	H2O
T°C (H2O)	30° C
Q Min (H2O)	1,5 (4m) -1,2 (8m)
P Min (H2O)	3 bar
P Max (H2O)	11 bar



TTS 18

Codice	Descrizione
605060000	Torcia TIG TTS 18 4m H2O
605070000	Torcia TIG TTS 18 8m H2O
605060000L	Torcia TIG TTS 18 4m H2O + Connettore 3 Poli
600976000L	Torcia TIG TTS 18 8m H2O + Connettore 3 Poli

Vista Esplosa e principali ricambi

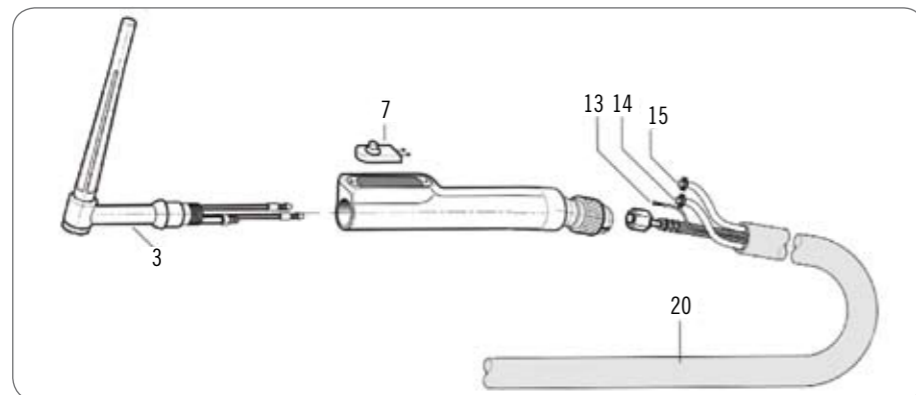

Ricambi

Codice	Descrizione	Posizione	Conf./Pezzi
6007780000	Corpo Torcia	3	1
6039900000	Micro - sottogomma	7	1
6007620000	Cavo comandi a mt.	13	1
6009050000	Tubo passaggio gas a mt.	14	1
6009030000	Tubo passaggio acqua a mt.	15	1
6008730000	Protezione in tela "TUBIX" a mt.	20	1

TIG TTS 20

Torçe Tig 250A H2O

Dati Tecnici TTS 18

V Class	L
Lz max (100% Argon)	250
V (Ac or Dc)	AC-DC
Ø Filo	1,0-3,2 mm
Gas	6-15 l/1'
Raffreddamento	H2O
T°C (H2O)	30° C
Q Min (H2O)	1,6 (4m) -1,2 (8m)
P Min (H2O)	3 bar
P Max (H2O)	10 bar



TTS 20

Codice	Descrizione
6048500000	Torcia TIG TTS 20 4m H2O
6067400000	Torcia TIG TTS 20 8m H2O
600704000L	Torcia TIG TTS 20 4m H2O + Conn. 3 Poli
600705000L	Torcia TIG TTS 20 8m H2O + Conn. 3 Poli
600708000L	Torcia TIG TTS 20 4m H2O + Conn. 7 Poli C016
600709000L	Torcia TIG TTS 20 8m H2O + Conn. 7 Poli C016

Vista Esplosa e principali ricambi

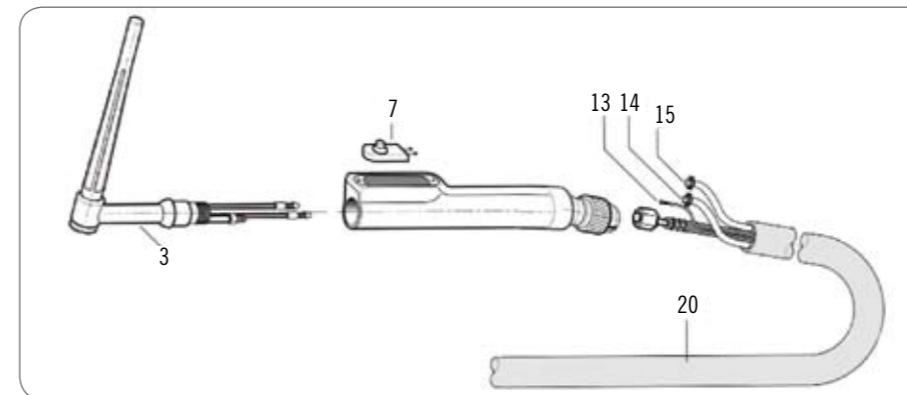

Ricambi

Codice	Descrizione	Posizione	Conf./Pezzi
6007770000	Corpo Torcia	3	1
6039900000	Micro - sottogomma	7	1
6007620000	Cavo comandi a mt.	13	1
6009040000	Tubo passaggio gas a mt.	14	1
6009020000	Tubo passaggio acqua a mt.	15	1
6008720000	Protezione in tela "TUBIX" a mt.	20	1

Consumabili TIG

TIG TTS 17V-26V-17-26-18

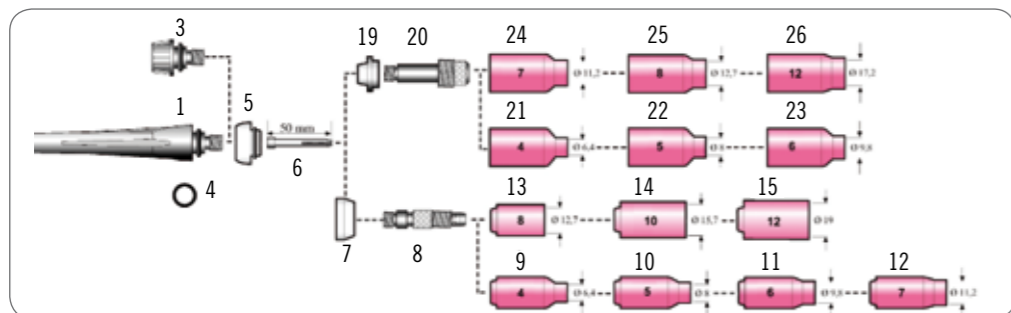

Consumabili

Codice	Descrizione	Posizione	Conf./Pezzi
600761000L	Cappello lungo completo 57Y02	1	5
600758000L	Cappello corto completo 57Y04	3	5
600752000L	Anello di tenuta OR 2037	4	10
600814000L	Guarnizione teflon lato cappello	5	5
600833000L	Pinza serra-elettrodo Ø.1,0 10N22	6	10
600835000L	Pinza serra-elettrodo Ø.1,6 10N23	6	10
600837000L	Pinza serra-elettrodo Ø.2,0	6	10
600839000L	Pinza serra-elettrodo Ø.2,4 10N24	6	10
600842000L	Pinza serra-elettrodo Ø.3,2 10N25	6	10
600844000L	Pinza serra-elettrodo Ø.4,0 54N20	6	10
600817000L	Guarnizione teflon lato ugello 18CC	7	5
600954000L	Porta pinza Ø.1,0 10N30	8	10
600955000L	Porta pinza Ø.1,6 10N31	8	10
600956000L	Porta pinza Ø.2,0	8	10
600957000L	Porta pinza Ø.2,4 10N32	8	10
600958000L	Porta pinza Ø.3,2 10N28	8	10
600959000L	Porta pinza Ø.4,0 406488	8	10
600911000L	Ugello ceramica GR.4 10N50	9	10
600912000L	Ugello ceramica GR.5 10N49	10	10
600913000L	Ugello ceramica GR.6 10N48	11	10
600914000L	Ugello ceramica GR.7 10N47	12	10
600915000L	Ugello ceramica GR.8 10N46	13	10
600908000L	Ugello ceramica GR.10 10N45	14	10
600909000L	Ugello ceramica GR.12 10N44	15	10
600815000L	Guarnizione teflon lato ugello Gas Lens	19	10
600845000L	Porta pinza Gas Lens Ø.1,0 45V24	20	10
600847000L	Porta pinza Gas Lens Ø.1,6 45V25	20	10
600849000L	Porta pinza Gas Lens Ø.2,4 45V26	20	10
600852000L	Porta pinza Gas Lens Ø.3,2 45V27	20	10
600854000L	Porta pinza Gas Lens Ø.4,0 45V28	20	10
600921000L	Ugello ceramico GR.4 54N18 Gas Lens	21	10
600924000L	Ugello ceramico GR.5 54N17 Gas Lens	22	10
600927000L	Ugello ceramico GR.6 54N16 Gas Lens	23	10
600931000L	Ugello ceramico GR.7 54N15 Gas Lens	24	10
600933000L	Ugello ceramico GR.8 54N14 Gas Lens	25	10
600917000L	Ugello ceramico GR.12 54N19 Gas Lens	26	10
600996000L	Elettrodo tungsteno ceriato Ø 1,0 (Grigio)	-	10
600997000L	Elettrodo tungsteno ceriato Ø 1,6 (Grigio)	-	10
600998000L	Elettrodo tungsteno ceriato Ø 2,4 (Grigio)	-	10
600999000L	Elettrodo tungsteno ceriato Ø 3,2 (Grigio)	-	10

Consumabili TIG

TIG TTS 20

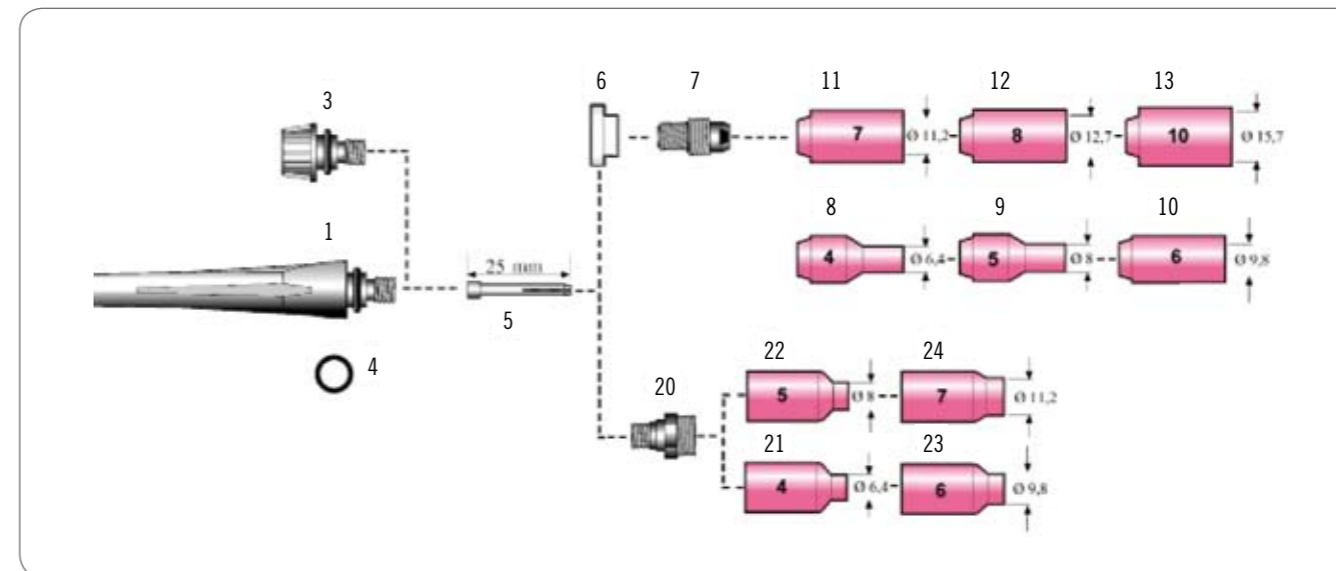

Consumabili

Codice	Descrizione	Posizione	Conf./Pezzi
600759000L	Cappello lungo completo 41V24	5	5
600757000L	Cappello corto completo 41V33	5	5
600563000L	Anello di tenuta OR 2018	10	10
600834000L	Pinza serra-elettrodo Ø.1,0 13N21	10	5
600836000L	Pinza serra-elettrodo Ø.1,6 13N22	10	10
600838000L	Pinza serra-elettrodo Ø.2,0	10	10
600564000L	Pinza serra-elettrodo Ø.2,4 13N23	10	10
600575000L	Pinza serra-elettrodo Ø.3,2 13N24	10	10
600813000L	Guarnizione teflon lato ugello 598882	5	10
600855000L	Porta pinza Ø 1,0 13N26	10	10
600856000L	Porta pinza Ø 1,6 13N27	10	5
600951000L	Porta pinza Ø 2,0	10	10
600566000L	Porta pinza Ø 2,4 13N28	10	10
600953000L	Porta pinza Ø 3,2 13N29	10	10
600576000L	Ugello ceramico GR.4 13N08	10	10
600567000L	Ugello ceramico GR.5 13N09	10	10
600925000L	Ugello ceramico GR.6 13N10	10	10
600928000L	Ugello ceramico GR.7 13N11	10	10
600932000L	Ugello ceramico GR.8 13N12	10	10
600846000L	Porta pinza Gas Lens Ø.1,0 45V42	10	10
600848000L	Porta pinza Gas Lens Ø.1,6 45V43	10	10
600851000L	Porta pinza Gas Lens Ø.2,4 45V44	10	10
600853000L	Porta pinza Gas Lens Ø.3,2 45V45	10	10
600919000L	Ugello ceramico GR.4 53N58 Gas Lens	10	10
600923000L	Ugello ceramico GR.5 53N59 Gas Lens	10	10
600929000L	Ugello ceramico GR.6 53N60 Gas Lens	10	10
600929000L	Ugello ceramico GR.7 53N61 Gas Lens	10	10
600996000L	Elettrodo tungsteno ceriato Ø 1,0 (Grigio)	-	10
600997000L	Elettrodo tungsteno ceriato Ø 1,6 (Grigio)	-	10
600998000L	Elettrodo tungsteno ceriato Ø 2,4 (Grigio)	-	10
600999000L	Elettrodo tungsteno ceriato Ø 3,2(Grigio)	-	10